



Approved:

Rally Director
Darius Šileikis
January 22, 2026

„Biorina Winter Rally Rokiškis 2026“

EVENT SAFETY RULES

The safety rules (further - Rules) of the automobile rally "Biorina Winter Rally Rokiškis 2026" (further - the Event) have been prepared in accordance with the provisions of Article 18 of the Law on Sports of the Republic of Lithuania and the regulatory acts of the Lithuanian Automobile Sports Federation (further - LASF). Participants and spectators of the event must comply with the safety requirements and prohibitions set by the organizer, specified in these Rules.

The organizer officially informs the LASF about the organization of this Event, and submits the Event Regulations (Additional Competition Regulations) and these Rules to the latter within the deadlines set by the latter.

I ARTICLE - SPECTATORS

1. The term "**track**" includes all special stages of the competition and each special stage separately. A special stage includes the section from the entrance to the time control post to the exit from the marking post (STOP sign) at the end of the special stage. The conduct of the competition on a special stage includes the period from the departure of the SAF car (yellow lights) from the start post to the passing of the „sweeper“ car (green lights) past the finish post.
2. Spectators must comply with the provisions of these Rules when observing the Event. In cases where other information means (rally personnel, signs, tapes, etc.) do not prohibit approaching the competition route or other dangerous places, spectators must comply with the provisions of these Rules.
3. Spectators must follow the instructions of the personnel working on the track.
4. The Organizer may set up special spectator zones for observing the competition (the conditions for spectator entry into and exit from the spectator zones are specified in the rally guide published by the Organizer). Spectator zones are set up in particularly safe places for observing the Competition.
5. Approaches and/or accesses to the tracks are indicated in the rally guide or competition maps published by the Organizer.
6. Spectators may also watch the competition in other locations, but only after familiarizing themselves with these rules and complying with the requirements specified in these rules.
7. It is prohibited to observe the competition in private areas (except in cases where permission has been obtained from the owner of the private area).

8. It is prohibited to consume alcoholic beverages and psychotropic substances while watching the competition. It is also prohibited to be in the competition observation area while intoxicated by alcoholic beverages or psychotropic substances.
9. Cars may suddenly change direction due to crew mistakes, mechanical failure of the car, track condition or terrain change, therefore the attention of the spectators must always be focused on the cars driving on the track. This allows them to notice the threat very early and retreat to an even safer place. At the competition observation point it is especially recommended: not to gather, not to sit, not to lie down, not to engage in any other activities, except for observing the competition.
10. It is prohibited to be (drive, walk, stand, lie down) on the roadway of the track and at a distance of at least 20 meters in both directions along the roadway of the track (red zone in the picture).

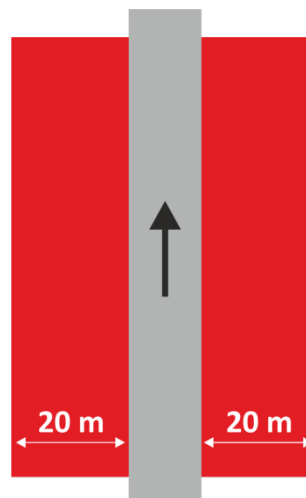

Straight section of the track

11. It is prohibited to be on the roadway and in the red marked areas around intersections, turns, jumps and retarders:

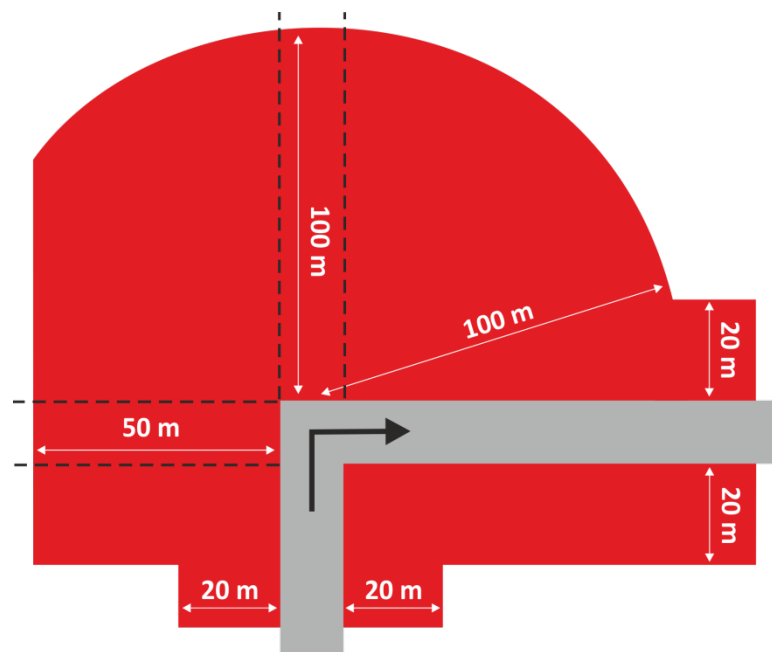

Turn of 90° or less (intersection)

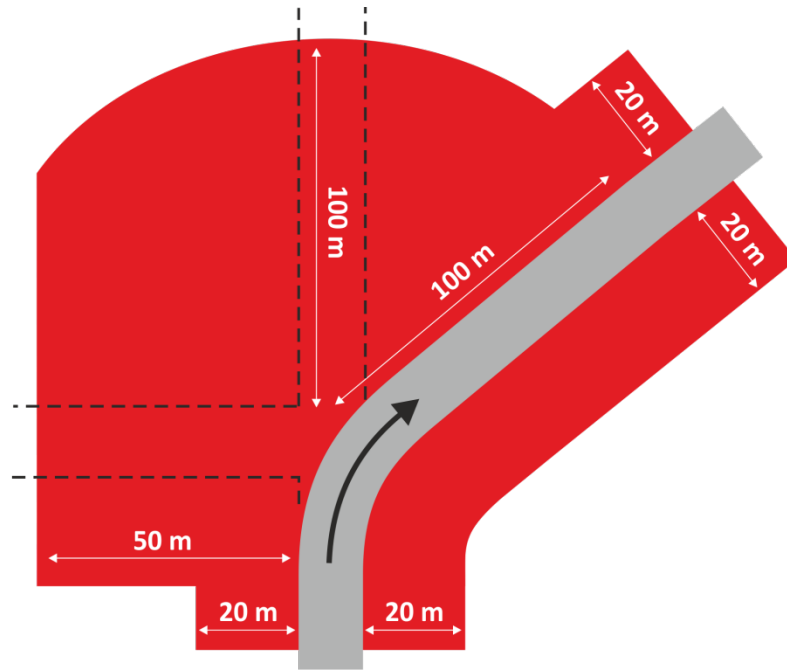

Turn of angle greater than 90° (intersection)

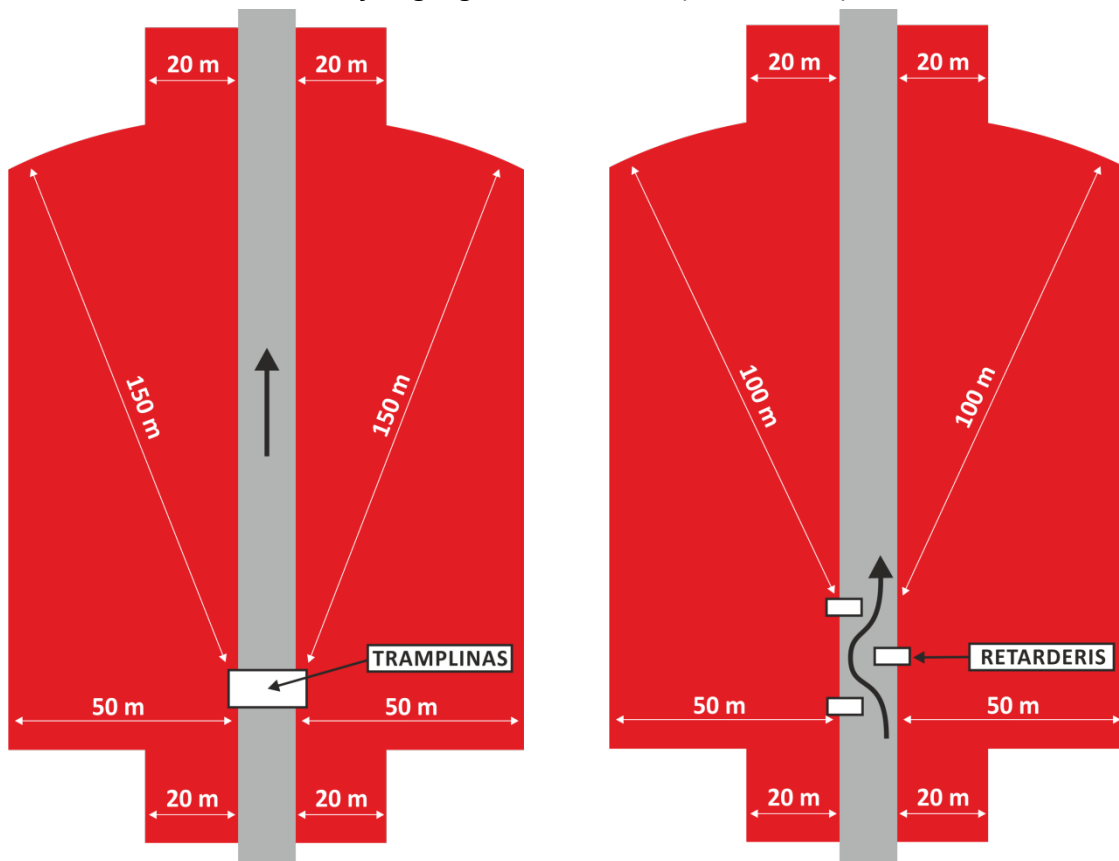

Jump and retarder on a straight section of the track

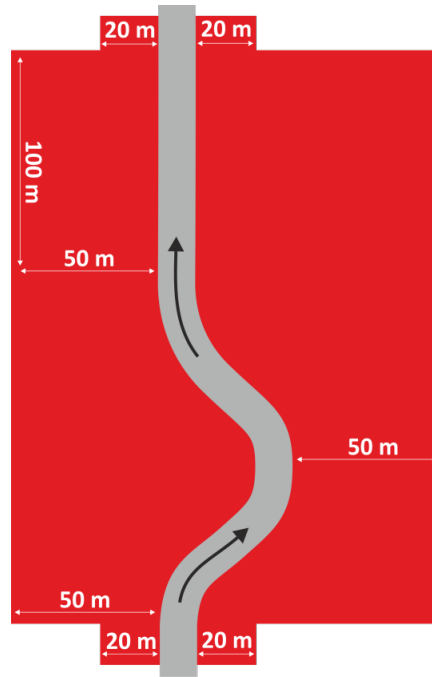

Turn sequence

12. In case of an accident or other unfortunate incident, spectators may only assist the injured if they are completely sure of their safety. If necessary, they must call for help. Spectators are prohibited from turning over an overturned vehicle if the crew member(s) are unconscious and are not in additional danger. It is also prohibited to unfasten the seat belts of the crew member(s), as this may cause additional injuries and may complicate the rescue operation. In the event of a fire in the vehicle, Spectators must only turn off the main electrical circuit switch, which may be located in the lower part of the front window and marked with the symbol:



In case a fire in a car, spectators should only activate the automatic fire extinguishing system, the switch or handle of which may be located in the lower part of the front window and marked with the symbol:





13. Upon the arrival of medics and rescuers, spectators must move away from the accident place at least 100 meters away and not interfere with the rescue operation.
14. The Organizer shall inform the spectators of the requirements of Article I of these rules by providing printed information at ticket purchase points and at the competition headquarters. The spectators shall also be informed of the requirements of Article I of these Rules when purchasing electronic tickets. These rules shall be published on the Organizer's website, social networks and other information sources. (www.winterrallyrokiskis.lt, *FB* <https://www.facebook.com/winterrally> and *INSTA* www.instagram.com/winterrallyrokiskis/).

II ARTICLE – PARTICIPANTS

15. The conditions for entry and exit of participants to the event places, specified places and objects to which participants are prohibited from entering, evacuation routes from the event places, conditions for safe conduct during the event, specific measures to ensure order and security in the event territory and its approaches are specified in the 2026 rally rules, regulations, technical regulations and supplementary regulations of this competition. The above-mentioned regulatory acts have been prepared in accordance with the regulatory acts of the FIA and LASF.
16. Participants shall familiarize themselves with the FIA and LASF regulations before they are issued with their driver's licenses (all documentation is available at www.fia.com and www.lasf.lt). Participants shall be familiarized with the additional regulations of the competition, the route and other documents on the organizer's website, social networks and other information sources. (www.winterrallyrokiskis.lt, *FB* <https://www.facebook.com/winterrally> and *INSTA* www.instagram.com/winterrallyrokiskis/).

III ARTICLE – FIRST AID

17. First aid is provided in accordance with the LASF First Aid description and the general legal acts of the Republic of Lithuania regulating first aid and medical aid.

IV ARTICLE – RESCUE TEAM

18. Rescue operations are carried out in accordance with the general legal acts of the Republic of Lithuania regulating rescue operations.